

BITMAIN

# APW3-12-1600 PSU Series User Guide

---

# Contents

1	Overview .....	3
2	Features.....	3
3	Specifications .....	4
4	Switching On/Off Remotely.....	5
5	Order Information & Wire Type .....	6
5.1	Order Information .....	6
5.2	Wire Types.....	6
6	Trouble Shooting & FAQ.....	7
7	Precautions for Use .....	8

## 1 Overview



The APW3-12-1600 series AC-DC PSU combines high efficiency and good dynamic performance into a power dense package. It also features overload, overheat, overcurrent and low voltage protection, making it well suited to 12V,  $\leq 1600\text{W}$  power devices.

**Please note:**

**1. This PSU cannot be used in countries with a mains power voltage is lower than 205V, the PSU will not start below this voltage.**

## 2 Features

- $\pm 20\%$  voltage input range
- High efficiency, up to 93.8%
- Short circuit, overload and overheat protection
- Extreme power density, 1U form factor
- 100% rated up to 50°C ambient
- C13 power connector
- 12 Month Warranty

### 3 Specifications

Output	DC Voltage	12V
	Rated Current	133A
	Rated Power	1600W
	Ripple & Noise	<1%
	Voltage Regulation	<2%
	Source Regulation	<1%
	Load Regulation	<1%
	Setup, Rise Time	<5S
	Power off Protection Trip Time	>10mS
	Interface Type	12 pairs of 6 pin PCI-E connectors. 450mm length for each PCI-E cable.
Input	Voltage Range	176-264V AC
	Starting Voltage	200-205V AC
	Frequency Range	47-63Hz
	Power Factor	>0.95 (full load)
	Leakage Current	<1.5mA (220V 50Hz)
	Interface Type	IEC320-C13
Protection	Low-voltage Input	171-181V AC
	Output Short Circuit	Yes
	Output Overcurrent	134-150A
	Overheat Protection	Yes
Environment Conditions	Operating Temperature	-20-50 °C @ 100%, -20-60 °C @ 80% load (refer to Load/Temperature graph)
	Operating Humidity	20% - 90% RH (non-condensing)
Structure	Dimensions	332mm*87mm*41mm
	Weight	2.3kg
Cooling	Fan Size	40mm*40mm*28mm
	Air Blowing Direction	From AC input to DC output

Max Load vs. Ambient Temperature Graph (220V input)

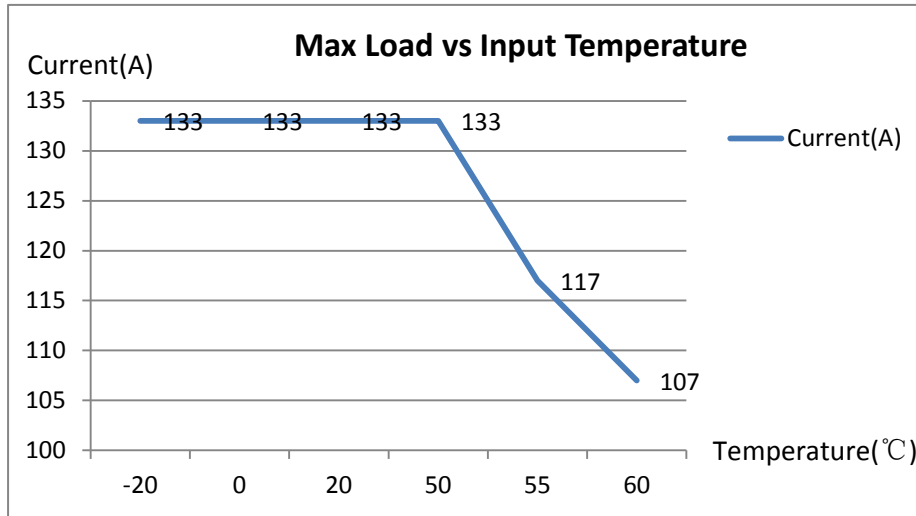

Efficiency vs Load (220V input)

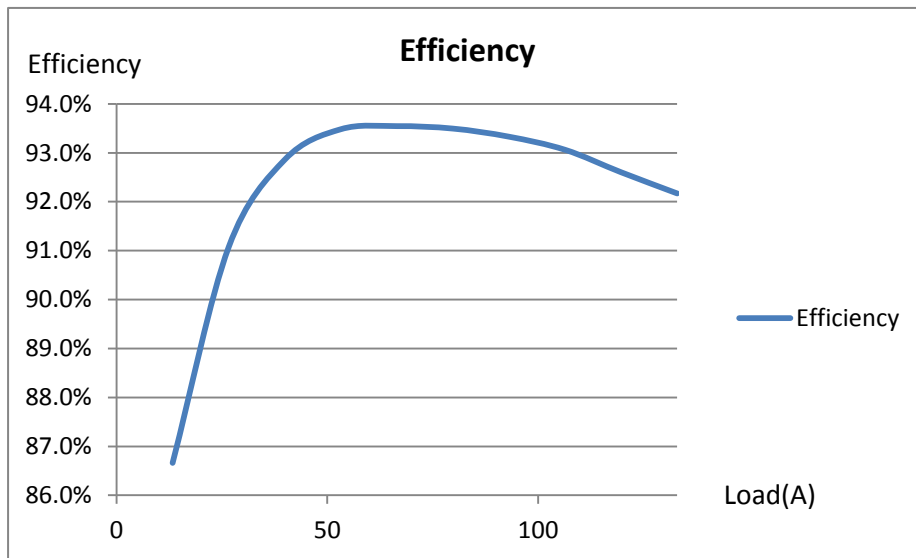

## 4 Switching On/Off Remotely

The PSU turns on automatically by plugging it into the mains. However, it also has a 3-pin port which can be used to remotely power the PSU on and off.

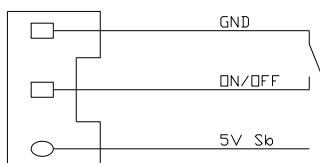

**Remote On/Off Method 1:** Use the physical power switch to control ON/OFF and GND lines,

closing the circuit turns the machine on, and breaking the circuit turns the machine off.

**Remote On/Off Method 2:** 5V sb PSU supports an external MCU, which controls a transistor or MOSFET to manage the ON/OFF pins to switch the PSU ON/OFF remotely. The PSU will turn on once power is provided to the 5V sb pin.

## 5 Order Information & Wire Type

### 5.1 Order Information

APW3-12-1600-B2

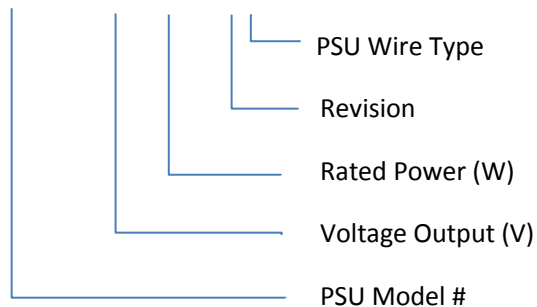

### 5.2 Wire Types



**Type 1:**  
4 pairs of M4 round terminal connectors and 1 PCI-E 6 pin connector



**Type 2:**  
12 pairs of 6 pin PCI-E connectors. 450mm length for each PCI-E.



## 6 Trouble Shooting & FAQ

#	Issue	Reason	Troubleshooting
1	Fan won't run, and no 12V output	AC Input is abnormal	<ol style="list-style-type: none"> <li>1. Make sure the AC input wire has a good connection and the plugs are connected firmly</li> <li>2. Make sure the mains power is working well and its voltage is above 205V.</li> </ol>
2	The fan is running, but there is no 12V output.	<ol style="list-style-type: none"> <li>1. Voltage in your power system is lower than required</li> <li>2. PSU is in protection mode</li> </ol>	<ol style="list-style-type: none"> <li>1. Please check whether the voltage is above 205V with multimeter to make sure the PSU can switch on correctly.</li> <li>2. Check whether there is a short circuit output or overload that is causing the PSU to enter a locked status. After removing the problem, the PSU should power up.</li> </ol>
3	After a few minutes, the PSU stops working, starts working, stops working and keeps cycling.	PSU is in over-heat protection	<ol style="list-style-type: none"> <li>1. Check whether the fan is working</li> <li>2. Check whether the fan's vent is being blocked</li> <li>3. Check whether there is a dust buildup inside the PSU due to prolonged use. Do NOT remove the PSU's cover unless trained to do so.</li> <li>4. Check the power and ambient temperatures follows the Load/Temperature graph</li> </ol>
4	Output is normal, but the fan is not working.	Fan is broken	<ol style="list-style-type: none"> <li>1. Check that the fan is clear of blockages or buildup</li> <li>2. Fan is broken and needs to be replaced.</li> </ol>
5	The PSU suddenly has no output and can't be started again.	The PSU is in over-current protection.	Check whether the load current has exceeded the built-in overcurrent protection limit. The protection automatically triggers when the load current exceeds the limit to protect against damage to the PSU and the server.

## 7 Precautions for Use

1. Before using the PSU, please ensure that the voltage and power outputs are compatible with your equipment.
2. Please ensure that the PSU appears to be in good shape and has not suffered damage in transit. If the exterior of the PSU appears damaged, do not use it.
3. Make sure that the metal cover for the PSU with on/off switch is properly grounded. Improper grounding is dangerous.
4. The PSU must be installed in such a way that it receives good, unobstructed airflow. Under no circumstances should the PSU be installed in an enclosed place.
5. When installing the PSU, please double check that the output polarities are the correct way round, and that the screws are fastened securely in place.
6. Do not attempt maintenance on any wiring while the PSU is powered up from the mains.
7. Running the PSU at <80% load or below can greatly prolong the life of the PSU. Usually, for every 10°C above the rated amount, the life of the PSU is cut in half.



**Regulation:**

**FCC Notice (FOR FCC CERTIFIED MODELS):**

This device complies with part 15 of the FCC Rules. Operation is subject to the following two conditions: (1) This device may not cause harmful interference, and (2) this device must accept any interference received, including interference that may cause undesired operation.

**Note:**

This equipment has been tested and found to comply with the limits for a Class A digital device, pursuant to part 15 of the FCC Rules. These limits are designed to provide reasonable protection against harmful interference when the equipment is operated in a commercial environment. This equipment generates, uses, and can radiate radio frequency energy and, if not installed and used in accordance with the instruction manual, may cause harmful interference to radio communications. Operation of this equipment in a residential area is likely to cause harmful interference in which case the user will be required to correct the interference at his own expense.

**EU WEEE: Disposal of Waste Equipment by Users in Private Household in the European Union**



This symbol on the product or on its packaging indicates that this product must not be disposed of with your other household waste. Instead, it is your responsibility to dispose of your waste equipment by handing it over to a designated collection point for the recycling of waste electrical and electronic equipment. The separate collection and recycling of your waste equipment at the time of disposal will help to conserve natural resources and ensure that it is recycled in a manner that protects human health and the environment. For more information

about where you can drop off your waste equipment for recycling, please contact your local city office, your household waste disposal service or the shop where you purchased the product.

**台灣 ROHS:**

設備名稱: _____, 型號: _____						
單元	有害物質					
	鉛 (Pb)	汞 (Hg)	鎘 (Cd)	六價鉻 (Cr+6)	多溴聯苯 (PBB)	多溴二苯 醚 (PBDE)
外殼	○	○	○	○	○	○
電路板組 件	—	○	○	○	○	○
其他線材	—	○	○	○	○	○
備考 1. “超出 0.1 wt %” 及 “超出 0.01 wt %” 係指限用物質之百分比含量超出百分比含量 基準 值。 備考 2. “○” 係指該項限用物質之百分比含量未超出百分比含量基準值。 備考 3. “—” 係指該項限用物質為排除項目						